

# RTU513 Remote Terminal Unit DataSheet & Connection settings

## Mounting Plate Rack WMS11

### Application

The Mounting Plate Rack WMS11 accommodates up to 2 communication unit CMU02 or 513CMB10 and up to 8 peripheral modules in a RTU513 substation. One more (extension) mounting plate rack can be connected to the WMS11 via the serial RTU513 system bus.



### Characteristics

A subrack, 3U high, to take single Europe format boards according to DIN 41494, is mounted on a printed circuit board with a height of 6U. The subrack has 9 slots for mounting one communication unit and up to 8 I/O modules.

It is possible to directly connect the process voltage of the input/output devices by using the integrated jumper field.

If a 513CMB10 is used, only power supervision is supported. To realize other functions a 513BCM02 is needed.

Another set of jumper is used to connect the minute interrupt of a real time clock RTC to the communication unit CMU02, if the clock is mounted in slot 2 (DIN 29).

A monitoring circuit on the mounting plate rack WMS11 checks the supply voltage of the boards (24 V DC, 5 V DC).

### Allocation of the slots:

- Slot 1 (DIN 34) for CMU02 (or empty)
- Slot 2 to 9 for max. 8 peripheral boards (DIN 29 to DIN 01)
- Slot 1½ for one 513CMB10
- Slot 3¼ for two 513CMB10

## Connections

The process signal cables are connected to plugin sockets with screw terminals or to connection pins for Standard Termi Point. The process signals can therefore be disconnected from the plug-in socket block at any time. The connection point#17 (PE) is not connected any more.

In addition to the process signal connections, the following interface possibilities are located on the rear side of the printed circuit board:

- Interface to the serial peripheral bus (SPB)
- External input for minute interrupt
- Power source connection
- Relay contact for monitoring the internal voltages (24 V DC and 5 V DC)
- Relay contact for 'Warnings' (Set by software)
- Inputs for process voltages, for direct distribution to the input/output devices

## Operation

The Mounting Plate Rack WMS11 can be mounted on mounting plates. The process signal access is done via plug-in terminals or standard TERMI-Point connectors.

The sub-rack has one dedicated slot for the communication unit CMU02, and eight slots for extension devices. These eight slots can be used for I/O sub-racks of the type CMU02. A mixed mode with CMU02 and 513CMB10 is only possible as protocol converter.

One additional sub-rack WMS11 can be assembled to the main rack, and will be connected via the serial peripheral bus (SPB) of the RTU513.

The position of the connectors and setting elements may be taken from Figure 6.

## Processing Functions

### Voltage Supervision, Alarms

Figure 1 shows the voltage monitoring system of the WMS11. The relay k1 is only switched on, if the 5 volt supply is present. Because the 5 volt is generated out of the 24 V DC supply by a DC/DC converter, both supply voltages for the sub-rack are monitored.

If one of the voltages is not present anymore the relay k1 is released and the contact closed (Figure 1).

The relay contact is connected to the plug-in terminals X6 and X7, in order to generate an alarm loop in the system.

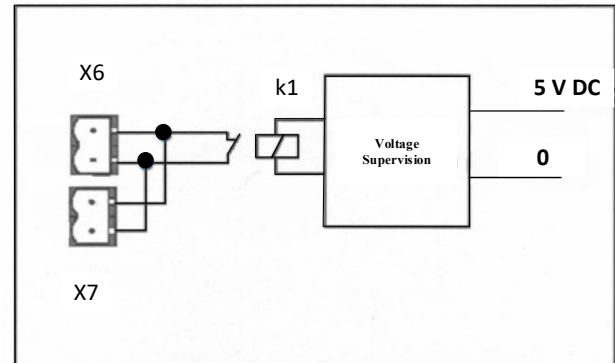

**Figure 1: Voltage Supervision**

In parallel the relay k1 is used by the firmware of the RTU513, in order to generate software alarms. Software alarms are configuration dependent events, which are described in the actual 'Functional Description' manual of the RTU513.

### Warnings

(Only CMU02)

The system warnings are connected to plug-in terminal X8. Software warnings are configuration dependent events, which are also described in the actual 'Functional Description' manual.

### Watchdog Function

(Only CMU02)

The integrated watchdog functionality is included on the Mounting Plate Rack WMS11, and will be re-triggered by the communication unit CMU02. If this trigger signal fails, the relay k1 is released and the contact is closed. The relay contact is connected to the plug-in terminals X6 and X7. The watchdog is active only if jumper X21 is set to position 2-3.

## Processing Functions

**Note:** If slot 1 (address DIN 33) is not used by the communication unit CMU02 (extension sub-rack), the jumper X21 has to be set to position 1-2, in order to disable the watchdog functionality.

### Minute Interrupt

(Only CMU02)

The minute interrupt of an external real-time clock receiver can be connected to plug-in terminal X4 (24 V DC), and will be routed to the communication unit CMU02.

If an internal real-time clock receiver RTC is used, it should be mounted into slot 2 (address DIN 29). The connection of the minute interrupt is done by the jumper X3 in Position 2-3.

**Note:** If slot 2 (address DIN 29) is used for another peripheral device than a real time clock RTC, the jumper X3 has to be set to position 1-2 (safe parking position), in order to Separate the digital part from the process voltage.

## 513CMB10 Applications

When a 513CMB10 is used, integrated functions like warnings, watchdog function and minute interrupt as well as the signaling contacts X6, X7, X8 and X4 are not supported. If warnings, watchdog function and minute interrupt are needed, an additional CMU02 has to be used. The use of a second 513CMB10 requires also an additional CMU02.

Jumpers X3 have to be set to position 2-1 and jumper X21 to 1-2 to activate voltage supervision.

## Rack Address

Each Mounting Plate Rack WMS11 must have a different rack address between 1 and 7. The rack address of the device is set by the switch register S1 (Figure 2).

S1-1	S1-2	S1-3	Rack address
ON	OFF	OFF	1
OFF	ON	OFF	2
ON	ON	OFF	3
OFF	OFF	ON	4
ON	OFF	ON	5
OFF	ON	ON	6
ON	ON	ON	7
S1-4 Not used			
			

Figure 2: DIP Switch S1 for Rack Address

## Serial Peripheral Bus

The RJ45 jacket connector X2 is used to connect the serial peripheral bus (SPB, Figure 3) to an additional Mounting Plate Rack 5. The serial peripheral bus has to be terminated by a 1 kΩ resistor on both ends. This resistor is installed after delivery.

## Serial Peripheral Bus

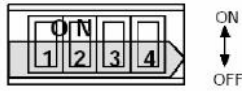
SPB Interface		
Pin	Signal	
1	-	Not used
2	TA	Data-
3	TB	Data+
4	-	Not used
5	GND	Ground
6	-	Not used
7	-	
8	-	
	Shield	Connected to the enclosure



Figure 3: Serial Peripheral Bus Connector X2

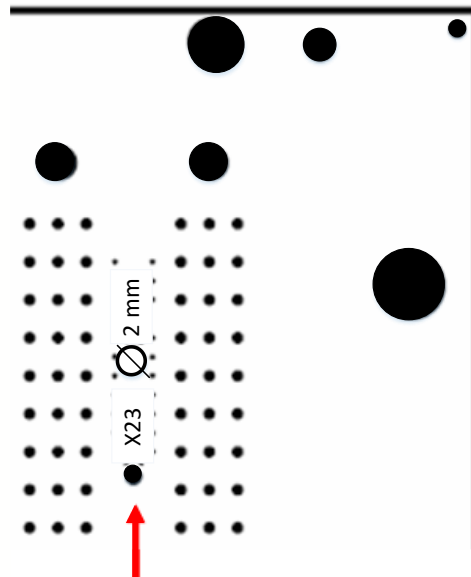

Figure 4: Position of X23

## Fiber Optic Coupler FOSM12

Use the fiber optic coupler FOSM12 for the serial peripheral bus, if a longer distance must be linked or the grounding situation is not clear.

## Power Supply

The supply power (24 V DC) has to be connected to plug-in terminal X5 and protected by the fuse F1 (4 A). Normally the external power supply unit is used for this purpose. If another power supply is used, it has to fulfill the following requirements:

- Over-voltage category II
- Secure separation to the SELV circuit according to EN 60950

## Signaling

There are three green light emitting diodes (LED) on the backplane. Two of them are used for monitoring the supply power 5 V DC and 24 V DC. The third LED is used for signaling the activities on the serial peripheral bus.

Because there is only one LED available for receive and transmit signals, this LED is nearly continuously on.

## Grounding

The Mounting Plate Rack WMS11 is equipped with two 6.3 mm FASTEN connectors for grounding. After delivery the 0V level is connected to the protection earth (PE). If the overall grounding concept of the whole plant makes it necessary to open this connection, it can be removed by using a 2 mm drill from the back side (lower left) of the PCB at position X24 (Figure 5).

## Grounding

makes it necessary to open this connection, it can be removed by using a 2 mm drill from the back side (lower left) of the PCB at position X24 (Figure 5).

All peripheral boards and the communication board CMU02 within the Mounting Plate Rack WMS11 have to be fixed in the subrack. Fasten each board by the two fixing screws in the upper and lower fixing rail.

The process cables must be grounded at the entrance of the cabinet, or on a separate terminal block inside the cabinet

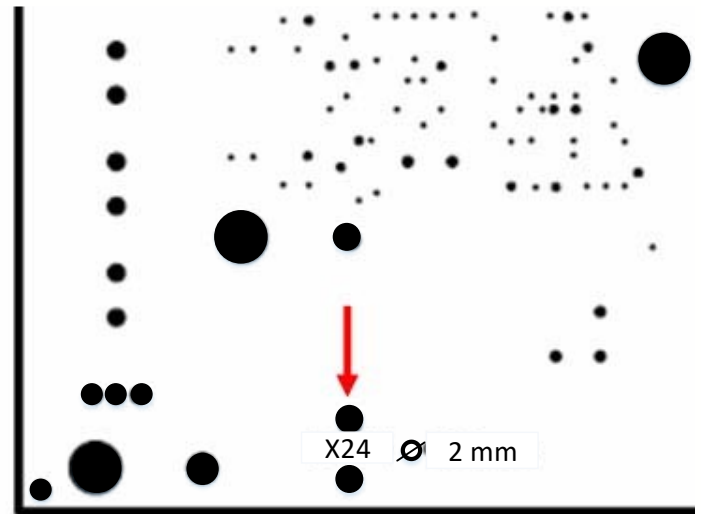

Figure 5: Position of X24

## Process Connection

By using the plug-in connectors X9 and X10 and the jumper blocks X9 to X20, it is possible to directly connect the process voltages to the common returns of the peripheral boards (Terminal 18 and 19). Figure 7 demonstrates the principle of these connections, and Figure 8 shows the safe parking position 3-4 and 7-8 of the jumper. This parking position is always used, if the integrated process connection is not used.

Figure 9 show the principle connection of the binary input board 16DIM10, the binary output board 16DOM10.

By using the jumper X9 to X20, the following limits may not be crossed, neither in total nor each of them:

Plug-in connector X9 / X10	max. 5 A each
Terminal Point 18 / 19	max. 2 A each
Terminal Point 1 to 16	max. 1 A each

## Mounting

The mounting plate rack WMS11 will be fixed on the mounting plate with 7 screws. Figure 13 and Figure 14 show the details. Figure 12 shows the position / size of the fixing holes.



Process Connection

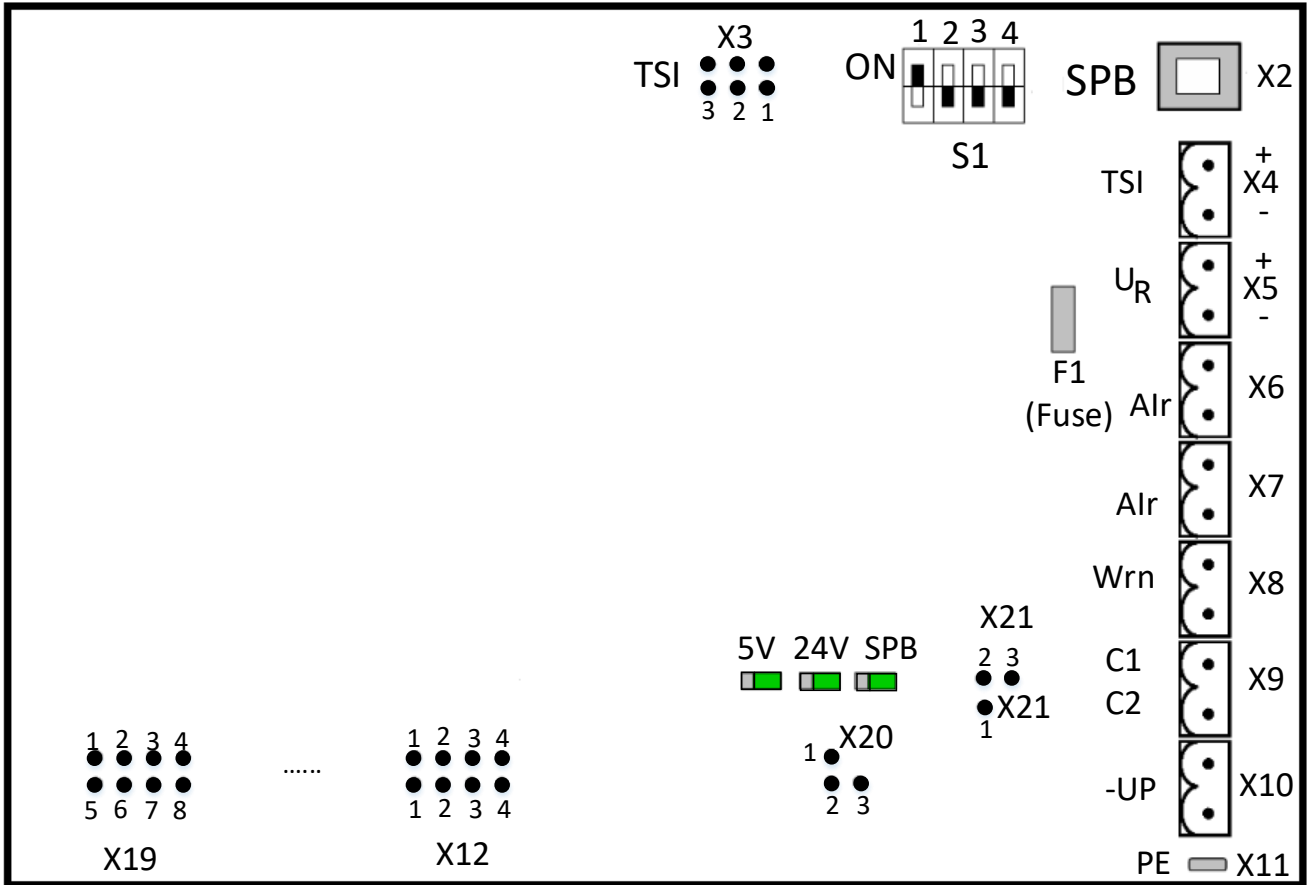

Figure 6: Position of Connectors and Setting Elements

Process Connection

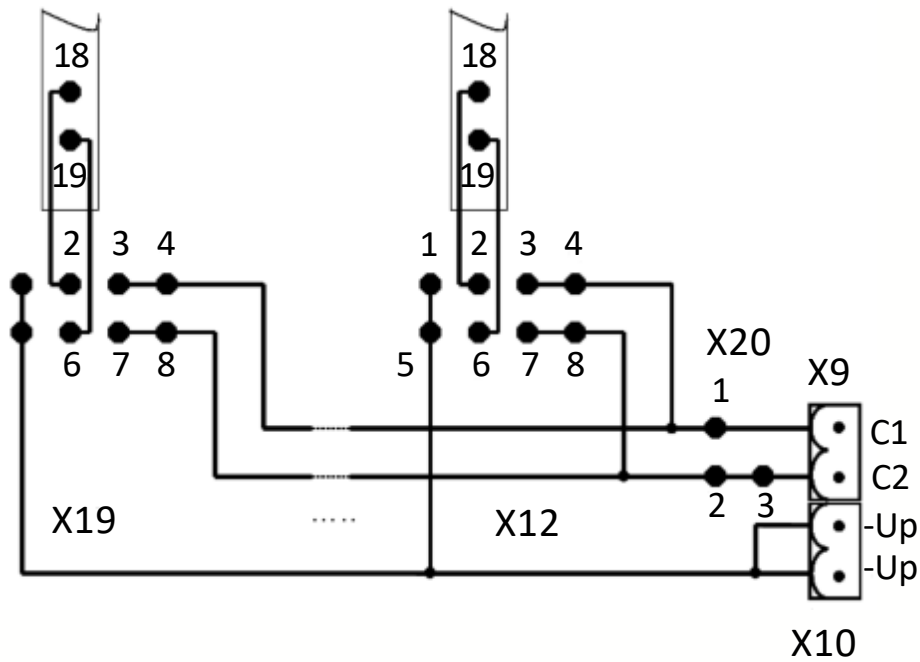

Figure 7: Drawing Principle of Process Connection

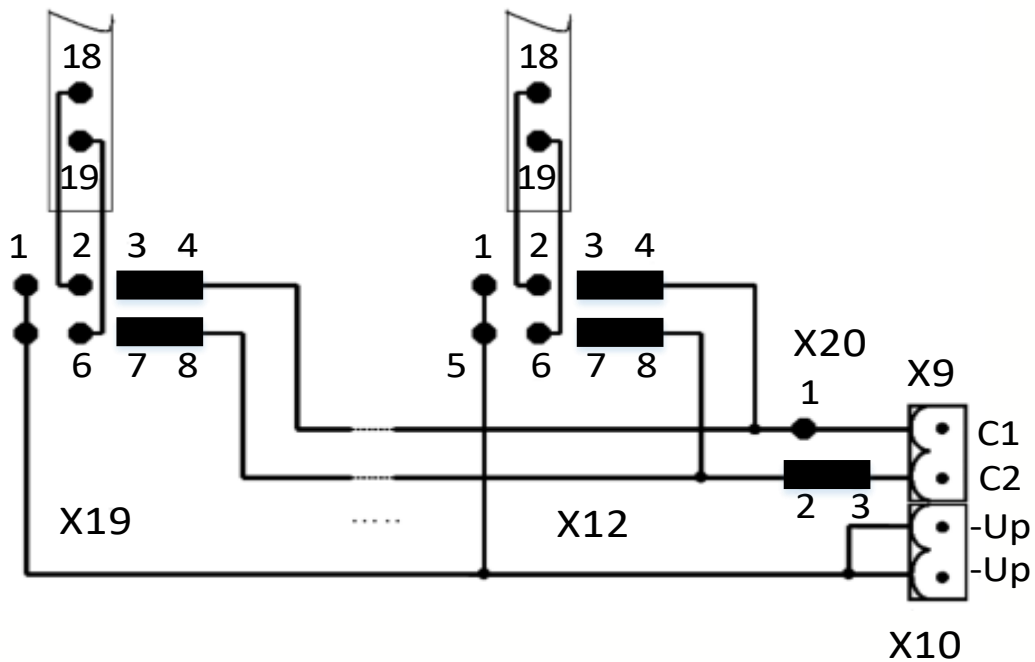

Figure 8: Safe parking Position of the Jumper

Process Connection

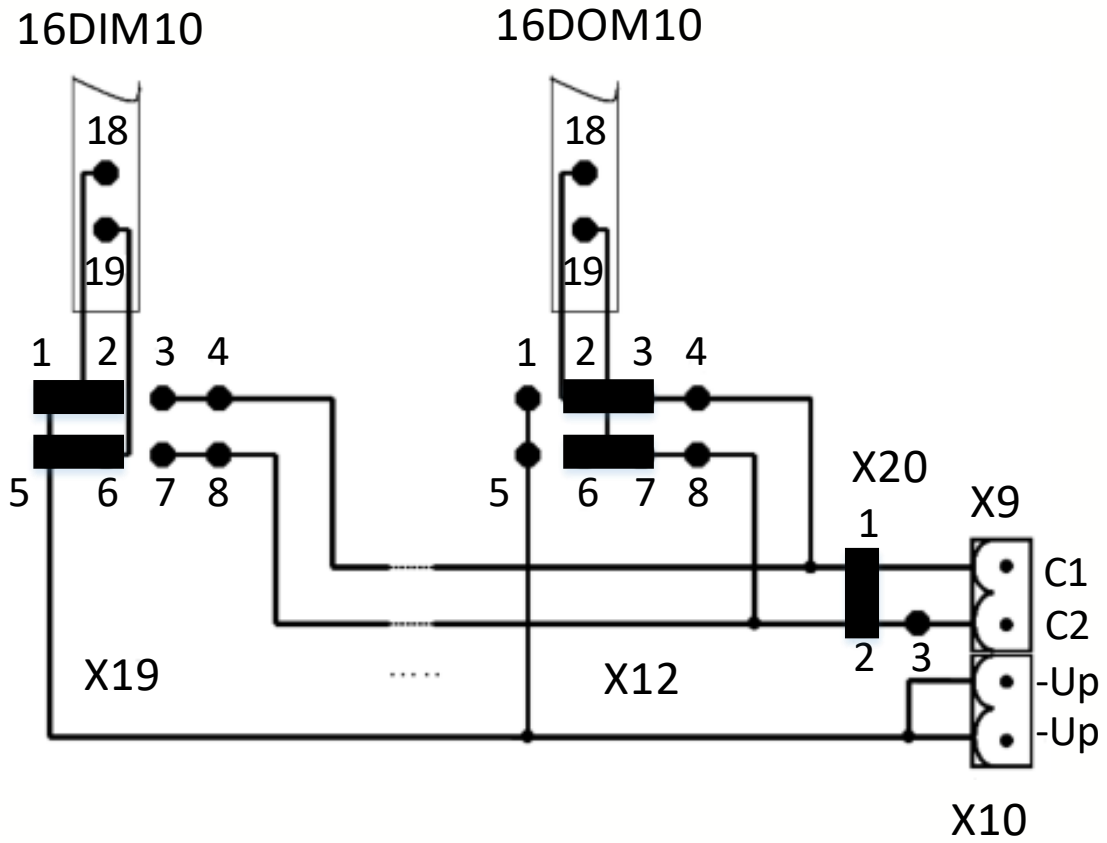

Figure 9: Connecting 16DIM10 and 16DOM10

Mounting Plate Rack WMS11

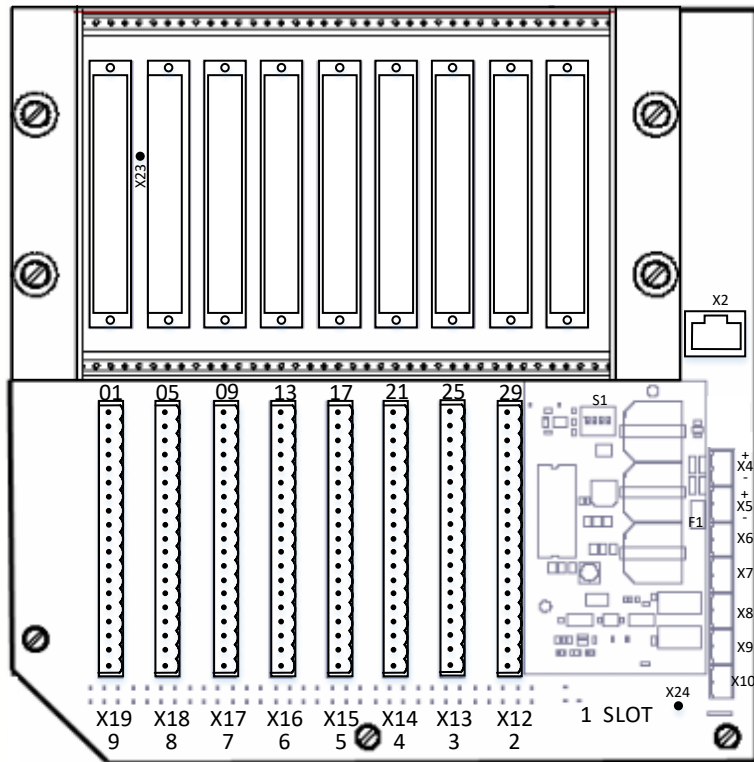

Figure 10 : Mounting Plate Rack, Front View

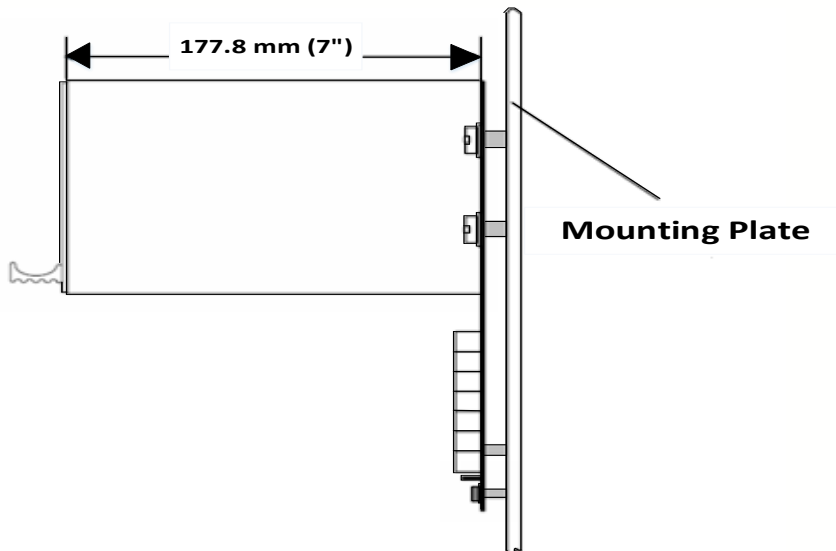

Figure 11 : Mounting Plate Rack, Side View

Mounting

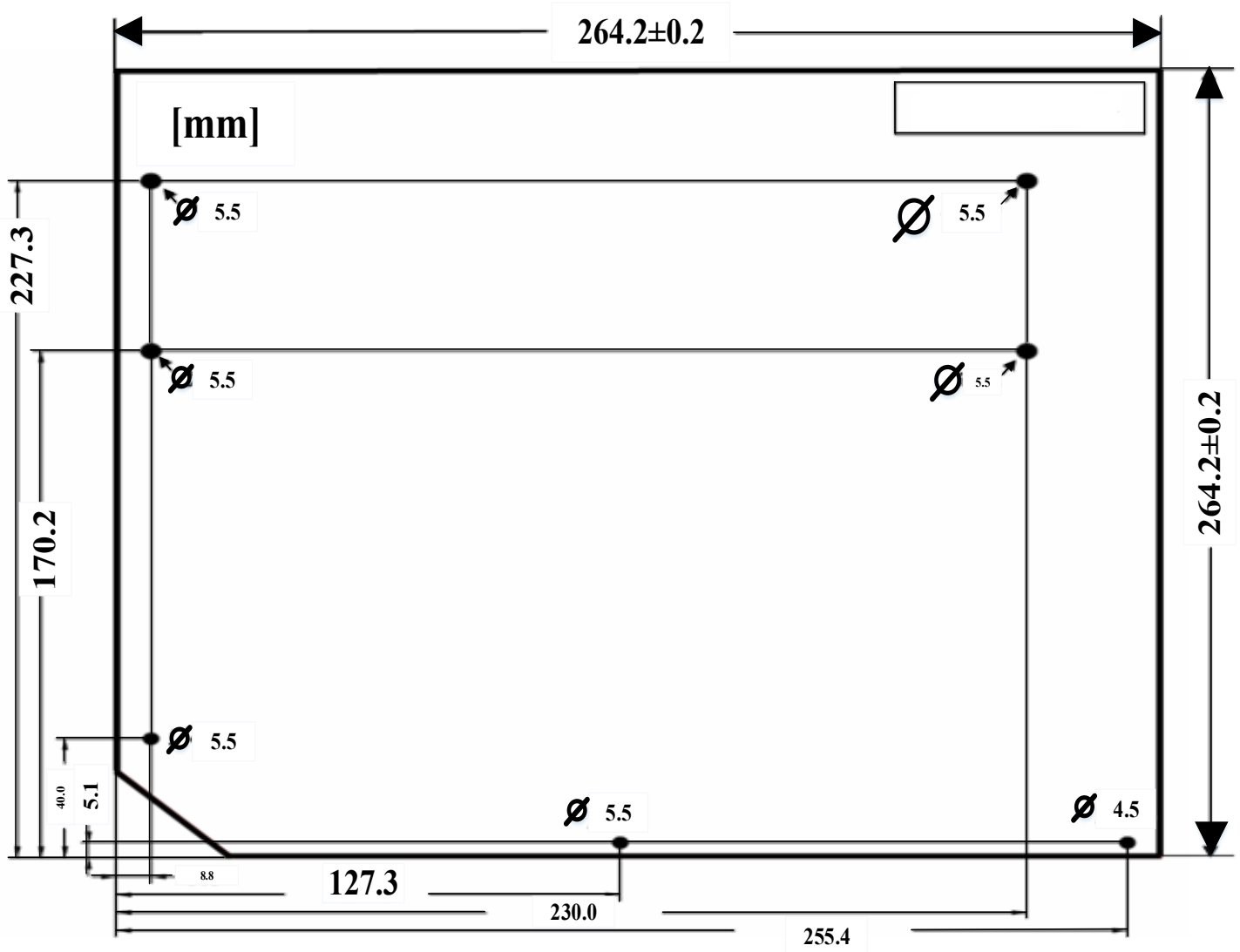

Figure 12: Position / size of the mounting holes

## Mounting

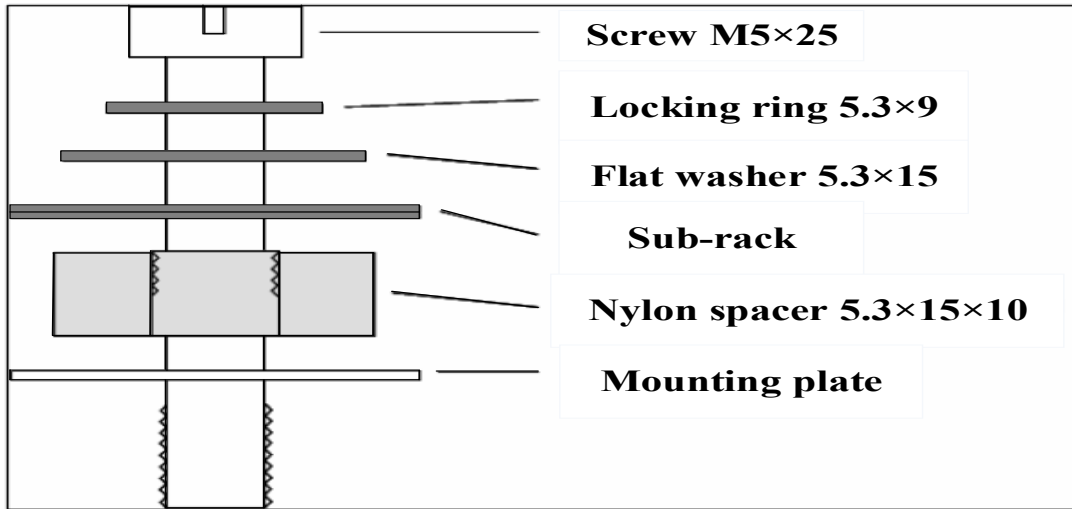

Figure 13: 4 screws for fixing the rack

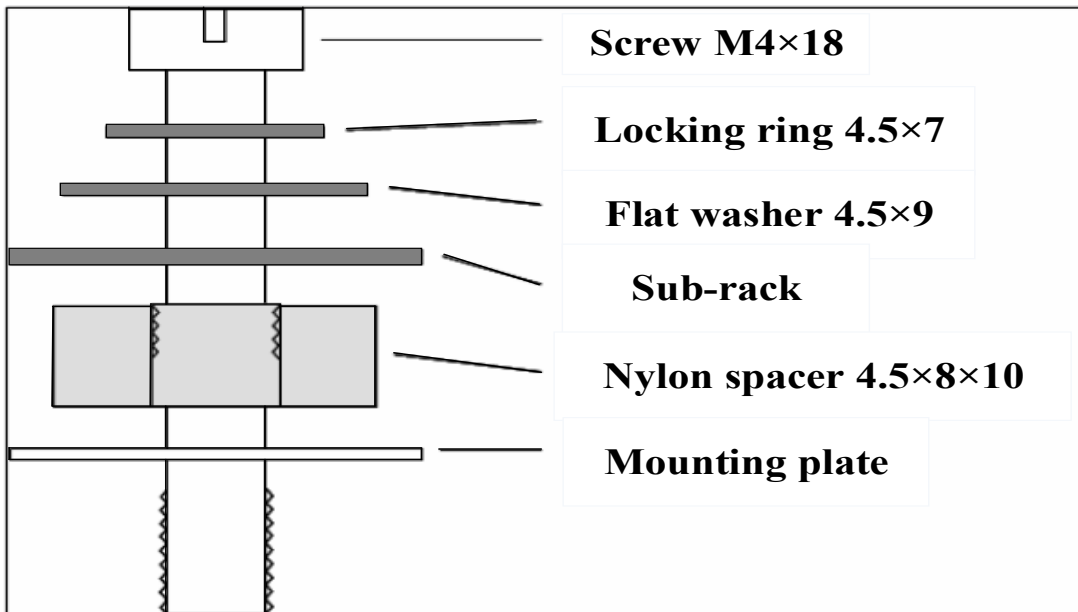

Figure 14: 3 screws for fixing the board

## Technical Data

In addition to the RTU513 general technical data, the following applies:

### Rack

Height 3 U, 9 slots according to DIN 41494 1 slot = 4 raster = 20,32 mm 132,8 x 192 x 178 mm (H x W x D)	
Mounting depth with boards	198 mm
... with boards and front plugs	248 mm

### Mounting Panel

Dimensions	266 x 265 mm (H x W)
Weight	1,4 kg

### Serial Interface

Peripheral Bus	RJ45 socket connector
----------------	-----------------------

### Connection Type

CMU, I/O boards	Indirect, 48 pole, Type F DIN 41612
Process signals	Plug-in terminal strip, 19 pole, 18 signals, shield not connected

### Connectors

Minute interrupt (TSI)	Plug-in terminal strip, 2 pole, 24 V DC
Power supply	Plug-in terminal strip, 2 pole, 24 V DC, 20.4 ... 28.8 V DC, Output (internally): 5 V DC, max. 5 A 24 VDC direct connect from 24 VDC input
Relay 'Alarm'	Plug-in terminal strips, 2 * 2 pole, relay contact: 1 A / 60 V DC, 30 W
Relay 'Warning'	Plug-in terminal strip, 2 pole, relay contact: 1 A / 60 V DC, 30 W
Process voltages: C1, C2 and -Up	Plug-in terminal strips, 2 * 2 pole, 60 V DC, max. 5 A
Protection earth	2 * Fasten 6,3 mm

### Protection

Fuse, SMD type F1	SMT FUSET 154 3820 125 V 4A (delayed), ex- changeable Manufacture: Little FUSE Order code: 154004TDR
-------------------	--

## Technical Data

### Electromagnetic Compatibility

Electrostatic discharge immunity test according to EN61000-4-2	6 kV Conducted 8 kV Air Performance criteria A
Radiated radiofrequency electromagnetic field immunity test according to EN61000-4-3	10 V/m Performance criteria A
Electrical fast transient/burst immunity test according to EN61000-4-4	2 kV Performance criteria A
Surge immunity test according to EN61000-4-5	2 kV (line to line) 2 kV (line to earth) Performance criteria A
Immunity to conducted disturbances, inducted by radio-frequency fields according to EN61000-4-6	10 V Performance criteria A
Oscillatory wave immunity test according to EN61000-4-18	2,5 kV (Common Mode) 1 kV (Differential Mode) Performance criteria A
Test for immunity to voltage dips/short interruptions according to EN61000-4-29	-100%: 11 ms Performance criteria A

### Safety

Information Technology Equipment according to EN60950-1, 03/2003	Over voltage category II, pollution degree II, reinforced insulation
--	--

### Interference

Electromagnetic disturbance characteristics according to EN55022 0.01 to 30 MHz	≤ 66 μV Class B
Electromagnetic disturbance characteristics according to EN55022 30 MHz to 1GHz	≤ 47 μV/m Class B

### Mechanical Stress

Vibration tests (sinusoidal) according to IEC60255-21-1, 05/1996, chapter 4.2, class 1	0.0350 mm 0.5 g at 10 ... 150 Hz
Mechanical influences (sinusoidal) according to IEC60870-2-2, 06/1998, chapter 4.2, class B	10 m/s <sup>2</sup> at 9 ... 200 Hz 15 m/s <sup>2</sup> at 200..500 Hz
Vibration, shock, bump and seismic tests according to IEC6025521-2, 05/1996, chapter 4.2, class 1	15 g, 25 g / 11 ms 6 impulse / ordinate 10 g / 16 ms 1000 impulse / ordinate
Seismic test	3.5 mm / 1 g / 1...9 Hz 9...35 Hz

### Environmental Condi-

Temperature:	0 ... 70 °C
Relative humidity:	5 ... 95 % (non condensing)