

RTU513 Remote Terminal Unit DataSheet

Communication Unit 513CMB10

Application

The 513CMB10 Communication Main Board is one of the CMU boards (CMU = Communication Main Unit) of the remote terminal unit RTU513. The essential tasks are :

- Managing and controlling of the I/O boards via the interfaces to the RTU peripheral bus
- Reading Process events from the input boards
- Writing commands to the output boards
- Communications with control centers and local MMI systems via the integrated serial line interfaces and the implemented Ethernet 10/100BaseT LAN interfaces
- Managing the time base for the RTU513 station and synchronizing the I/O boards
- Handling the dialogue between RTU513 and Web-Browser via LAN interface



Within the RTU513 subracks the board occupies two slots. It contacts itself via a DIN F socket connector to the subrack .

The Communication Unit 513 CMB10 is available in one version for RTU peripheral bus and UART-based communication protocols.

Characteristics

The two microprocessors are the essential hardware parts of the board, which share themselves in the tasks:

- MPU: 32 Bit Main Processing Unit
- SLC: 8 Bit Serial Line Controller

The SLC works as master for the RTU peripheral bus.

The MPU is responsible for the other tasks. The MPU handles the absolute time and date for the RTU. The real time clock (RTC) can be used for the time reference or the time may be set and synchronized from the central system via the serial lines or via the Ethernet LAN interface.

Characteristics

RTU 513 synchronizes itself to the time references supplied by RTC . The minute pulse signal and the time information of the RTC are provided to the 513CMB10 on the backplane of the subrack

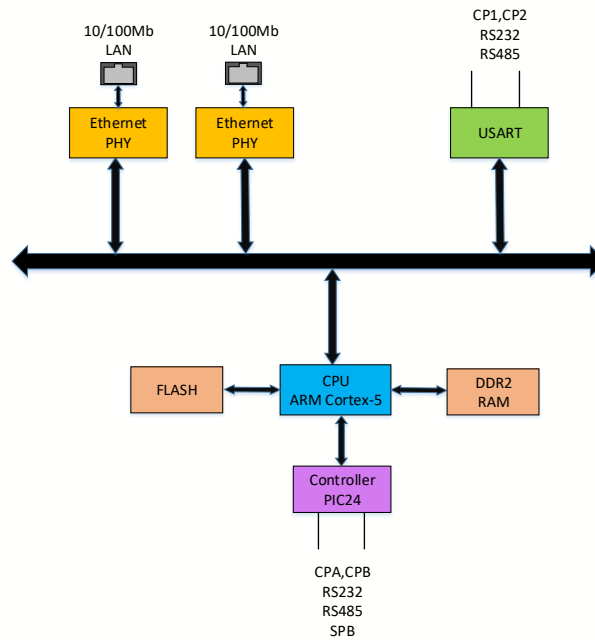

Fig. 1: Block diagram communication unit 513CMB10

The control unit stores configuration files power fail save in a removable Compact Flash memory card . That allows the RTU513 to have valid configuration data after power on and RTU513 will be available again after a short initialization.

The serial communication interfaces 1, 2, A and B are designed for RS232C and RS485 standard.

The interfaces 'E1' and 'E2' are based for the Ethernet standard 10 Base T/100 BaseT.

The connectors of the serial and Ethernet communication interfaces are provided as RJ45 jacks integrated in the board's front plate

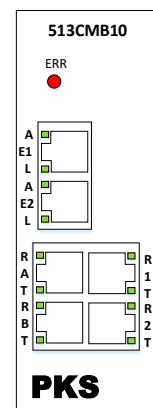

Fig. 2: Front plate 513CMB10

Characteristics

The RTU513 serial peripheral bus is connected to the communication interfaces A and B.

Furthermore communication interface B is directly connected to the back side, if it is used for the serial peripheral bus.

513CMB10 indicates operational and error states by a light emitting diode on the front plate. The exact definitions for this LED have to be taken from the functional description of the RTU513. the subrack

ERR	(1x) red	Error/Warning
TXD	(4x) green	Transmit data, Communication Port 1,2,A,B
RXD	(4x) green	Receive data, Communication Port 1,2,A,B
A	(2x) green	Ethernet Activity E1,E2
L	(2x) green	Ethernet link E1,E2

Operation

The 513CMB10 controls process events and communications with control centers and local MMI systems via up to four serial interfaces (CP1, CP2, CPA, CPB) and the two Ethernet 10BaseT/100BaseT LAN interfaces (E1, E2).

The module has one jumper X1 (see Fig. 7 and 8), to force the IP-address of the Ethernet interface to a default value. If the jumper is set to 1-2 after a restart, the Ethernet interface E1 will be initialized with the IP-address 192.168.0.1 (Subnet mask 255.255.255.0, Gateway 192.168.0.20).

The connection to the RTU513 Serial Peripheral Bus (SPB) and the RTU513 System Bus is done via 48 pole DIN-F socket connector according to DIN 41612.

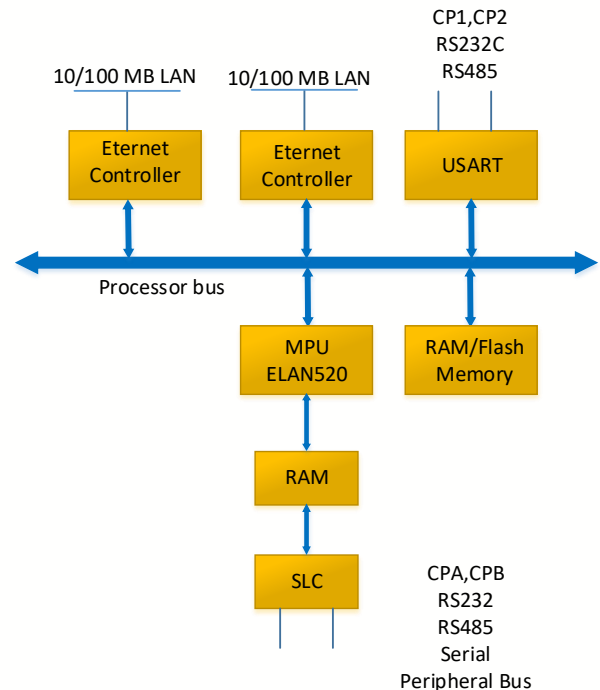

Fig. 3: Block diagram 513CMB10

Serial Interface

The serial interfaces are available on the RJ45 connector on the front plate. It can interface RS232C (Figure 4) or RS485 (Figure 5) signals.

Pin	Signal	Input/Output
1	DCD	Input
2	RxD	Input
3	TxD	Output
4	DTR	Output
5	GND	-
7	RTS	Output
8	CTS	Input
	Shield	Connected with housing

Fig. 4: Serial Interface RS232C Mode

Pin	Signal	Meaning
1	-	Not used
2	TA	Data -
3	TB	Data +
4	-	Not used
5	GND	Signal Ground
6	-	Not used
7	-	Not used
8	-	Not used
	Shield	Connected with housing

Fig. 5: Serial interfaces RS485 Mode

Communication speed, parity, used modem signals and other communication parameter are set by the tool RTUtil513 only.

In RS485 mode, both sides of the serial bus must be terminated by a 1 kΩ resistor. The termination on the CMU side is already done onboard.

CP1 and CP2 Interface

The CP1 and CP2 interfaces connected to an USART (universal synchronous/asynchronous receiver/transmitter) can interface RS232C or RS485 signals. On both interfaces different UART based protocol types can be used.

CP1 and CP2 Interface

Possible limitations can be found in the document:

- [1KGT 150 620 V001 1] Interfaces and Protocols
- 1KGT 150 714

CPA and CPB Interface

The functionality of the interfaces CPA and CPB depends on the used version (Rubrik) of the communication unit.

CMU 513CMB10 R0001

The communication interfaces CPA and CPB have two different functions:

- Serial Peripheral Bus (SPB) connection
- UART character based protocols

Both functions are mutually exclusive. The SPB allocated always both interfaces in parallel. In this case the interface CPB is automatically routed to the 48 pole DIN-F socket connector of the CMU.

If the interfaces are running in UART-mode, both interfaces can handle different communication protocols.

CMU 513CMB10 R0002

The version R0002 of the communication unit is able to handle in addition non UART character based communication protocols on CPA and CPB. An overview of these protocols can be found in [1KGT 150 620 V001 1].

CPA and CPB can be used only for the same non-UART based protocol type at a time.

Ethernet Interfaces

The Ethernet interfaces on the Front plate supports different functions.

- Webserver-diagnostic with download of configuration files and firmware

Ethernet Interfaces

- Protocol IEC 60870-5-104, DNP3, ...
- Integrated HMI

The signals are used according to Fig. 6.

Pin	Signal	Input/Output
1	TD+	Output
2	TD-	Output
3	RD+	Input
4	-	Not used
5	-	Not used
6	RD-	Input
7	-	Not used
8	-	Not used
	Shield	Connected with housing

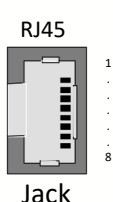

Fig. 6: Ethernet Interfaces E1, E2

Signaling

The red LED (ERR) of the 513CMB10 is under software. The definition and operation of the LED must be taken from the release specific function description. The LEDs “TxD” and “RxD” are directly connected to the receiver / transmitter of the communication line. The LEDs “A” and “L” are directly connected to the Ethernet-controller.

Signaling

LED	Color	Meaning
ERR	red	Warning / Error
TxD	(4x)green	Transmit data (CP1, 2, A, B)
RxD	(4x)green	Receive data (CP1, 2, A, B)
A	(2x)green	Ethernet Activity
L	(2x)green	Ethernet Link

Table 1: Meaning of LEDs

Firmware Version

The actual firmware version will be delivered on a Compact Flash memory card. A new firmware file can be loaded with the Web diagnostic tool into the removable Compact Flash memory card.

Changing of Compact Flash memory cards is possible.

Settings

The settings of the hardware and for operation of the communication interface of the 513CMB10 have to be taken with the RTUtil560 configuration tool.

The settings of the communication parameters can be done in the "Hardware Tree" of the RTUtil513.

For the RTU513 serial peripheral bus protocol the settings are predefined. For other protocols the parameters have to be defined according to the protocol type.

The following parameters have to be defined for all protocols:

- Interface Type
- Baudrate: 50 to 19 200 baud
- Carrier pre-time

Modem control:

- Direct link (TxD/RxD only)
- WT link full duplex (no handshake)
- WT link half duplex (RTS/CTS handshake)
- WT link half duplex (RTS / DCD handshake)
- Dial up (external modem DCD handshake)

Settings

- Loop switch unit (RP570/71 Host interface only, DSTC 3002)
- Link with collision avoidance (DCD handshake, DNP 3 only)

The settings of the Ethernet interfaces are:

- node name(s)
- IP address(es)
- Subnet mask(s)
- Default Gateway(s)

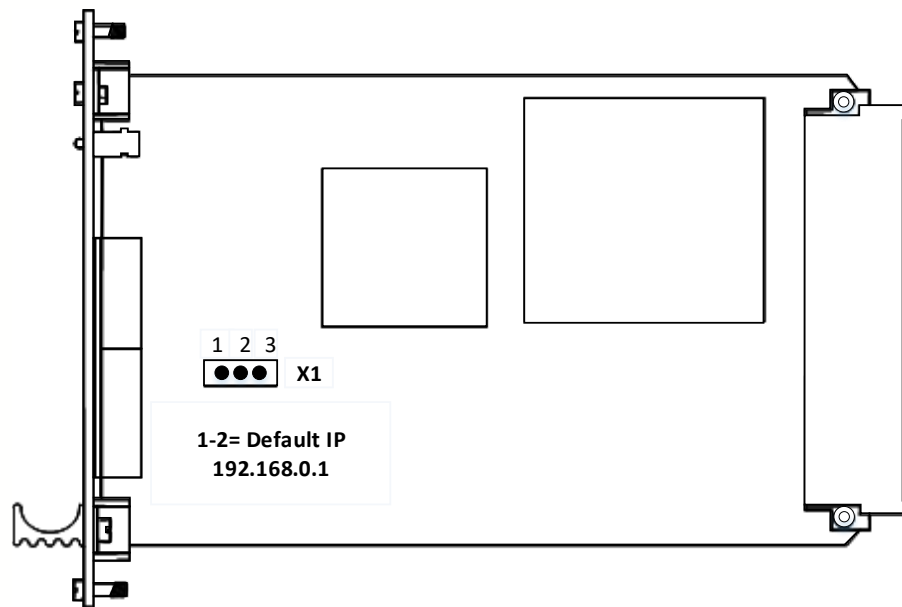

Fig. 7: Position of Jumper X1

Settings

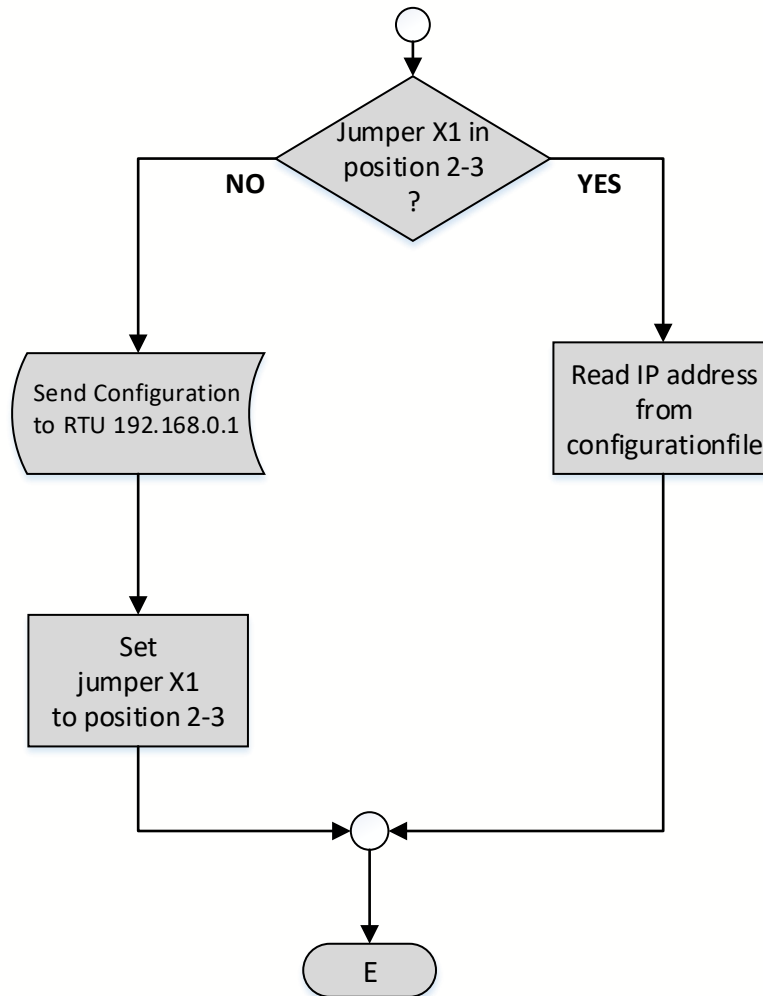

Fig. 8: Use of jumper X1

Technical Data

In addition to the RTU513 general technical data, the following applies:

Main Processing Unit MPU

Microprocessor	ELAN520 @ 133 MHz (incorporating an Intel 586™ class 32 bit processor)
RAM	64 MByte
Flash Memory	128 MByte (CompactFlash)

Serial Line Controller SLC

Controller Type	80C251
RAM	32 kByte
Dual Ported RAM	16 kByte

Ethernet LAN Interfaces E1 and E2

Physical Interface:	10BaseT/100BaseT
Bit rate:	10/100 MBit/s

Serial Interfaces 1, 2, A and B

The physical Interface is switchable between RS232C and RS485 by the configuration tool RTUtil513

Physical Interfaces	RS232C
Bit rate	≤ 38 400 bit/s
Signal lines RS232C	GND E2/102 TXD D1/103 RXD D2/104 RTS S2/105 CTS M2/106 DTR S1.2/108 DCD M5/109
Physical Interfaces	RS485
Bit rate	≤ 19 200 bit/s
Signal lines RS485	G Signal ground A Receive/Transmit B Receive/Transmit

Power Consumption

5 V DC	1060 mA
--------	---------

Technical Data

Mechanical Layout

Printed Circuit	3HE, Euro-card format (160 x 100 mm)
Front Panel	8R, 2 slots (40 mm)
Weight	approx. 0.3 kg

Connector Types

Subrack connector	Indirect, 48 pole Type F DIN 41612
Ethernet Interfaces	RJ45 jack, 8 pole
Serial interfaces 1, 2, A and B	RJ45 jack, 8 pole

Ordering Information

513CMB10R0001	R0001
---------------	-------

Environmental Conditions

Temperature	0 ... 70 °C
Relative humidity	5 ... 95 % (non condensing)